

## Distribution of the vibration effect within the stacked boxes during vehicular road transportation of tomatoes

C.L. Ranatunga<sup>1\*</sup>, H.H.E Jayaweera<sup>2</sup>, S.K.K Suraweera<sup>2</sup> and T.R.Ariyaratne<sup>2</sup>

1. Dept of Physics, Faculty of Applied Sciences, University of Sri Jayewardenepura, Nugegoda, Sri Lanka

2. Centre for Instrument Development, Department of Physics, Faculty of Science, University of Colombo, Colombo 03, Sri Lanka.

\*Corresponding author

Received on : 30-07-2014

Accepted on: 13-10-2014

### Abstract

Parameters of the Road-Vehicle-Load system influence the vibration effects generated at vehicular road transportation. Vertical vibration acceleration (PSD<sub>max</sub>) experienced by the tomato boxes and tomatoes within the box was studied using the popular transport means in Illukkumbura area in Matale. The road quality was estimated using the International Road Roughness Index (IRI). Fully loaded Mitsubishi Canter truck at an average speed of 20 kmh<sup>-1</sup> on a road rated at IRI between 2 to 3.5 mm/m registered increasing trend in the PSD of vibration from the front side towards the rear side of the truck in the horizontal direction. The observed average PSD values are in the approximate ratio, front : middle : rear  $\approx 1 : 3 : 6$ . Also the PSD of the vibration was found to be amplified from the bottom stack towards the topmost stack in the vertical direction. The observed average PSD values at 1<sup>st</sup>, 2<sup>nd</sup>, 3<sup>rd</sup>, and 4<sup>th</sup> stacks are in the approximate ratio, 1 : 1 : 1.5 : 2.5. PSD of vibration was studied with a fully loaded truck at different speeds on a road consisting of segments rated at varying IRI. The fully loaded truck at different speeds on a road consisting of segments rated at varying IRI registered varying PSD values of vibration. Even at lower speeds such as 25 kmh<sup>-1</sup> the vibration acceleration produced at "poor" quality (IRI > 5 mm/m) roads was nearly 4 times higher compared to that produced at "fair" (IRI 2 to 3.5 mm/m) or "good" quality (IRI 0.9 to 2 mm/m) roads. Registered pattern of the PSD appears to be similar at the tomato boxes and at the tomatoes within the same box.

**Key words :** Vehicular Road transportation, Vehicular vibration, Power spectral density of vibration, Road-vehicle-load system, Road roughness, Stacked cargo.

## Introduction

Shock and vibration effects produced during vehicular road transportation can result in damage to the commodity. The vibration component with the largest effect during the vehicular road transportation is the vertical vibration (Holt and Schoorl, 1985, Hinsch et al., 1993, Vursavus and Ozguven, 2004). Level of effective vibration and the induced damage to the commodity depends on many factors within the road-vehicle-load system. Firstly, the factors related to the road and vehicle. One must pay attention to the aspects such as road quality (roughness of the road), type of vehicle, its suspension system, tires, inflated air pressure and driving speed. Secondly, the factors related to the load or the commodity. Serious attention must be paid to the nature of the commodity, packing pattern of the commodity within containers (crates or boxes) and the loading pattern of the containers on the vehicle. Fruits & vegetables (F&V) are delicate living materials. Damage inflicted on the F&V is rather devastating compared to that occurred on hard, rigid materials such as building materials. The damage to F&V can also be inflicted during harvesting, handling, and even during storing.

Since the parameters pertaining to the road-vehicle-load system highly influence the vehicular vibration, it requires dealing with them appropriately when studying the distribution of the vertical vibration acceleration produced across the stacked tomato crates during transportation. The power spectral density (PSD) or the acceleration spectral density (ASD) shows the variation of the square of the acceleration i.e. (acceleration)<sup>2</sup> as a function of the frequency (Tustin, 2005). In other words, PSD indicates frequencies at which the vibration effects are strong and weak. The unit of PSD is energy per frequency width. Acceleration is expressed in “g” units where 1 g is equivalent to 9.8 ms<sup>-2</sup>. Power spectral density in acceleration studies is simply equal to the square of overall acceleration level divided by the frequency bandwidth (i.e. g<sup>2</sup>/Hz) (Tustin, 2005). A very large range of PSD can be represented by a convenient number when the logarithmic ratio – Decibel (dB) – is used with a suitable reference acceleration level. An acceleration of 0 dB implies the acceleration level of interest is equal to that of the reference. Hence, PSD expressed in dB/Hz unit is commonly used in comparison work of vibration acceleration (Aster and Borchers, 2008, Northwood-Labs-LLC, 2003).

Hinsch et.al. reported in 1993 that the peak of the vertical vibration acceleration (PSD<sub>max</sub>) registered at the rear end of the truck in fruit & vegetable transportation

is nearly eight times higher compared to that at the centre of the truck and both peaks were produced between 2 to 3 Hz. Also they reported that the trucks having steel spring suspension system produce marked vibration effects compared to those having air-ride suspension systems. Studies carried out with stacked tomato boxes loaded on a steel spring truck show that higher the stacked level of the box, the higher was the PSD<sub>max</sub> of the vertical vibration acceleration. The tomato box stacked at the topmost (3<sup>rd</sup>) stack level experienced nearly four times higher PSD<sub>max</sub> compared to that experienced by the box at the bottom of the stack. Also it was reported an up-shift of the frequency at which the PSD<sub>max</sub> occurs to the region from 8 Hz to 9 Hz with the stacked tomato boxes (Hinsch et al., 1993).

## Materials and Methods

Sensitive elements of the road-vehicle-load system in this study were treated as given below.

### Road quality

Road roughness was estimated using the Present Serviceability Rating (PSR) and then quantified using the International Road Roughness Index (IRI). PSR is the subjective method of judgment of an observer (essentially a driver) of the road as to serve the traffic it is meant to serve. PSR judgment is made on a subjective scale ranging from 0 to 5. The method proposed by Al-Omari and Darter 1992 (Equation 1) was used to compute the IRI based on the PSR data (<http://www.umtri.umich.edu>).

$$IRI = -\frac{1}{0.26} \log_e \left( \frac{PSR}{5} \right) \quad \text{----- (1)}$$

Road quality and typical PSR and IRI values are given in **Table 1**.

**Table I.** Road quality and typical PSR and IRI values

Road quality	PSR	IRI (mm/m)
Very poor; Impassable	0	∞
Very poor	1	6.2
Poor	2	3.5
Fair	3	2.0
Good	4	0.9
Excellent	5	0.0

A 68 km distance of road from Rathkinda (Matale province) to Dambulla was selected for this study. Each 500 m segment of the road was evaluated by a panel of judges for its average PSR. The average speed and the average PSD level of the vibration acceleration experienced within the segment of road were recorded. The average PSR was used to estimate the road quality in terms of the International Road Roughness Index (IRI) using equation 1.

### Vehicle parameter

Mitsubishi Canter FE 535B6R truck model was used for this study. Important vehicle parameters are as given below.

#### Suspension

Front :- 01 set of Leaf Springs + 01 set of Shock Absorber.  
Rear :- 01 set of Leaf Springs + 01 set of Shock Absorber + 01 set of Helper Spring.

Gross Vehicle Weight Rating (GVWR)	:-	5,500 kg
Kerb weight (original body)	:-	2,225 kg
Recommended payload	:-	3,275 kg
Tire	:-	Ceat 700 – 16 LT
Tire-diameter	:-	760 mm
Tire-air pressure	Front	:- 65 psi
	Rear outer	:- 65 psi
	Rear inner	: 55 psi

### Load profile

Vegetable boxes were of approximate dimensions 0.60 m x 0.24 m x 0.30 m and empty box weighs from 2 to 4 kg. A box filled with tomatoes weighs from 20kg to 25 kg. Stacked vegetable boxes (152 Nos.) loaded on the truck bed has the configuration shown in **Figure 1(a)**. Total payload rises to a mass from 3,000 kg to 3,500 kg and it is clear that the load is very much closer to the upper limit of the recommended payload capacity.

### Vibration acceleration measurement

Steval MK1006V1 evaluation kit based on the LIS 302DL tri-axial linear MEMS accelerometer was used to measure PSD values of vibration. The “Board” configuration of the accelerometer was used to apply on flat surfaces such as truck-bed and tomato boxes. The “Ball” or the “artificial fruit” configuration was used to apply the accelerometer among tomatoes within tomato box.

For the estimation of the PSD, the accelerometers were attached/ implanted at the following positions.

1. at the front end , middle and the rear end of the empty truck-bed.
2. at the front end, middle and the rear end of the loaded truck-bed.
3. at the tomato layer just below the topmost layer in the tomato boxes loaded at different stack levels **Figure 1 (b)**.
4. at the topmost layer of the tomatoes in the **boxes** loaded along the truck at the 4<sup>th</sup> stack i.e. F4, M4, and R4 in **Figure 1 (c)**.
5. at the topmost layer of the tomatoes in the **boxes** at the 1<sup>st</sup>, 2<sup>nd</sup>, 3<sup>rd</sup> and 4<sup>th</sup> stack loaded at the rear end of the truck i.e. R1, R2, R3 and R4 in **Figure 1 (c)**.

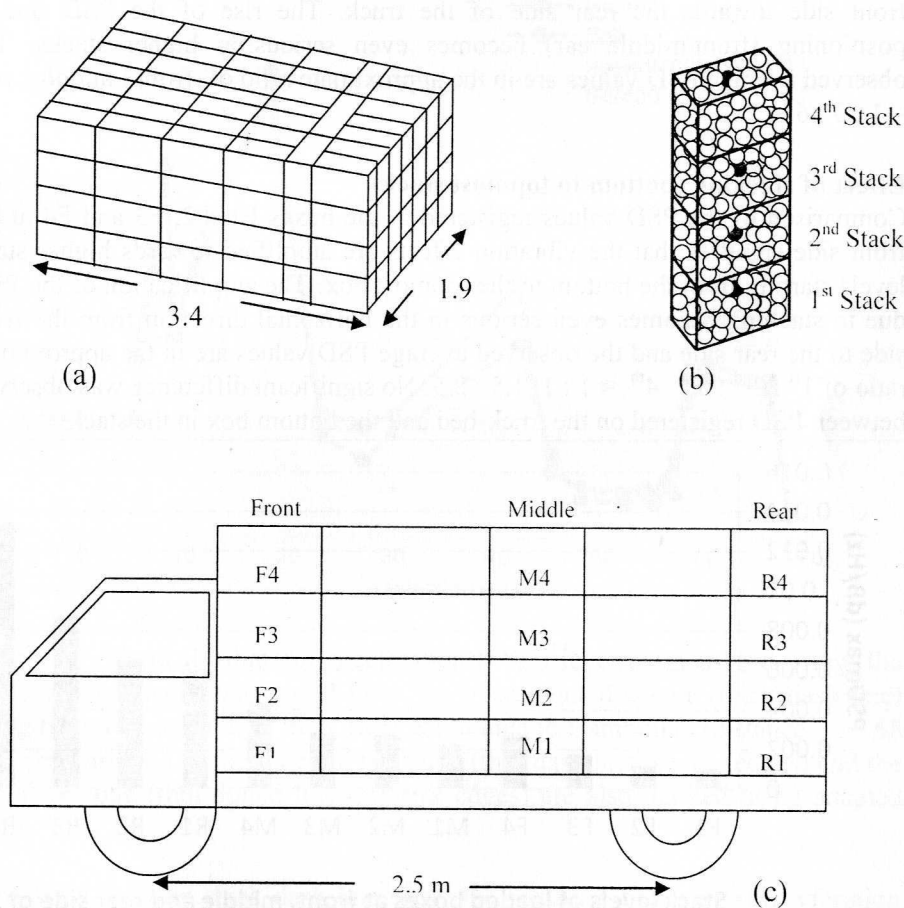

**Figure 1.** Pattern of stacking tomato boxes,  
 (a) on the truck bed at the fully loaded configuration  
 (b) in a single column  
 (c) boxes selected from front, middle and rear stacks

## Results

The variation of the vertical vibration acceleration level (PSDmax) registered at different stack levels at the front end, the middle and the rear end of the truck during the transportation at an average speed of  $20 \text{ kmh}^{-1}$  along a selected segment of road rated at PSR 2 to 3 (or IRI 3.5 to 2 mm/m) is shown in the **Figure 2**.

### Effect position (front/middle/rear) on the truck-bed

PSD values registered at the boxes F1, M1 and R1 at the 1<sup>st</sup> stack reveal that the vibration effects at the 1<sup>st</sup> stack level rise up in the direction starting from the front side towards the rear side of the truck. The rise of the PSD due to positioning (front/middle/rear) becomes even serious at higher stacks. The observed average PSD values are in the approximate ratio of, front : middle : rear  $\approx 1 : 3 : 6$ .

### Effect of stacking (bottom to topmost stack)

Comparison of the PSD values registered at the boxes F1, F2, F3 and F4 at the front side signifies that the vibration effects are amplified towards higher stack levels starting from the bottom to the topmost box. The amplification of the PSD due to stacking becomes even serious in the horizontal direction from the front side to the rear side and the observed average PSD values are in the approximate ratio of 1<sup>st</sup> : 2<sup>nd</sup> : 3<sup>rd</sup> : 4<sup>th</sup>  $\approx 1 : 1 : 1.5 : 2.5$ . No significant difference was observed between PSD registered on the truck-bed and the bottom box in the stack.

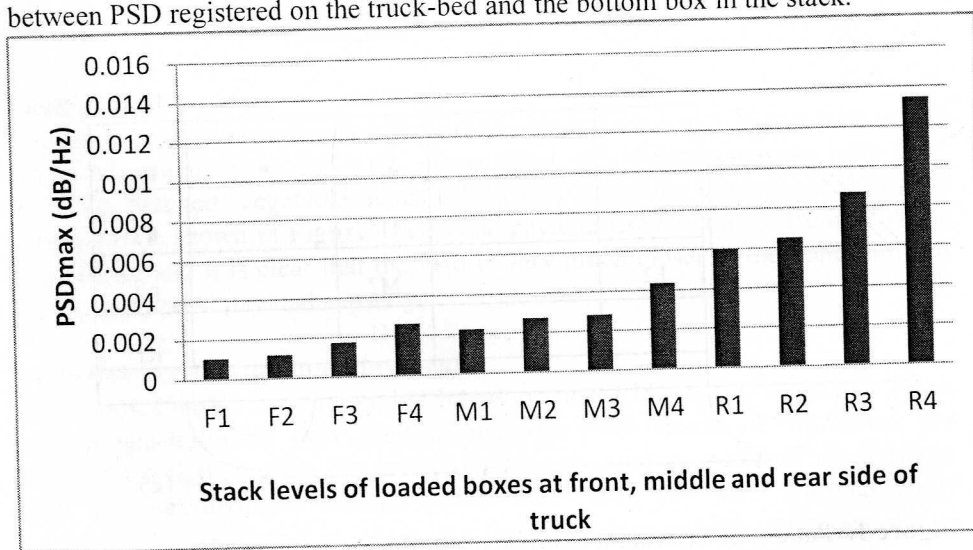
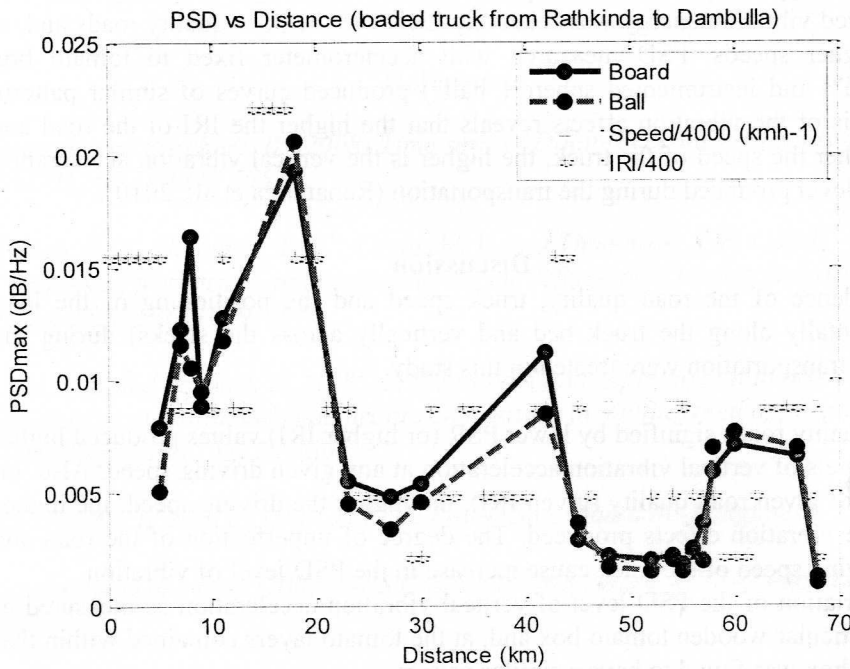

**Figure 2.** Summary of the results obtained on effective PSD levels of vertical vibration acceleration at different stack levels at front, middle, and rear of the truck bed. Average truck speed  $20 \text{ kmh}^{-1}$  on fair road PSR 2 to 3 (or IRI 3.2 to 2 mm/m).

**Effect of the speed and the road quality**

The vertical vibration acceleration as felt at the front topmost box (F4) during the ride of fully loaded truck along a 68 km distance from Rathkinda to Dambulla was determined. The variation

of the IRI of the road, the speed of the truck, the PSD as measured with the accelerometer attached to the tomato box (“Board” configuration) and the instrumented sphere implanted among tomatoes (“Ball” configuration) in the same box are shown in **Figure 3**.



**Figure 3.** Vertical vibration acceleration (PSD) level as measured using, the accelerometer board (thick solid line), the instrumented sphere (thick dash line) during the transportation of truck from Rathkinda to Dambulla (distance 68 km). The variation of the speed of the truck (thin dash line; square edges) and the IRI of the road (thin dotted line; asterisk edges) are also marked using adapted scales.

Thick solid line and thick dash line show the variation of the vertical vibration acceleration (PSD) as measured by the “Board” and “Ball” configurations of the accelerometer respectively. The thin dash line (with square marks) shows the variation of the truck speed. The thin dotted line (with asterisk marks) shows the variation of the IRI along the road. The same y-axis scale is used to express the quantity “(Speed/4000)” in km/h and the quantity “(IRI/400)” in mm/m. As

expected, the PSD of the vertical vibration acceleration generated by the truck bed closely follows the variation of the IRI value of the road.

The first 20 km distance of the total journey of 68 km, was a “poor” quality road (IRI > 5 mm/m). The last 20 km distance of the road was of “fair” quality (IRI 2 to 3.5 mm/m) or “good” quality (IRI 0.9 to 2 mm/m). Even at lower speeds such as 25 kmh<sup>-1</sup> (restricted by bumps, potholes and kerbs), the vibration energy generated at the “poor” quality road was relatively higher. It was nearly a 4 times higher energy compared to that experienced at “fair” or “good” quality road. The generated vibration energy was relatively higher at the poor quality roads and, at the higher speeds. PSD measured with accelerometer fixed to tomato box (“board”) and instrumented sphere (“ball”) produced curves of similar pattern. Analysis of the vibration effects reveals that the higher the IRI of the road and the higher the speed of the truck, the higher is the vertical vibration acceleration (PSD) level produced during the transportation (Ranatunga et al., 2010).

### **Discussion**

Dependence of the road quality, truck speed and the positioning of the load (horizontally along the truck bed and vertically across the stacks) during the tomato transportation were treated in this study.

Poor quality roads signified by lower PSR (or higher IRI) values produced higher PSD levels of vertical vibration acceleration at any given driving speed. Also, on a road of given road quality (given IRI), the higher the driving speed, the higher was the vibration effects produced. The degree of imperfection of the road and the driving speed of the truck cause increase in the PSD level of vibration.

The variation of the PSD level of vertical vibration acceleration as measured at any particular wooden tomato box and, at the tomato layers contained within that tomato box was found to have a similar pattern.

During the transportation of tomatoes in stacked boxes, the tomato boxes loaded at the rear side experience higher PSD levels of vertical vibration acceleration compared to those loaded at the front side of the truck. The PSD levels registered at tomato boxes rise up starting from the front side towards the rear side of the truck bed in the horizontal direction. Stacking causes amplification of vertical vibration acceleration at all positions front, middle and the rear of the truck bed. The boxes loaded at the topmost (4<sup>th</sup>) stack registered highest vibration effect compared to those loaded at the bottom of the stack at all positions front, middle and the rear of the truck bed. In general, at any given stack level, the registered PSD levels at the tomato boxes loaded at the front, middle and the rear ends were in the approximate ratio, Front: Middle: Rear  $\approx$  1:3:6. The amplification of the PSD level vertically across the stacked boxes was in the approximate ratio, 1<sup>st</sup> Stack: 2<sup>nd</sup> Stack: 3<sup>rd</sup> Stack: 4<sup>th</sup> Stack  $\approx$  1: 1: 1.5: 2.5.



Results show that the parameters of the road-vehicle-load system can inflict detrimental effects especially on delicate fruits and vegetables during their transportation.

### **Acknowledgements**

Authors wish to acknowledge the financial support of the National Science Foundation (NSF) under the research grant RG/2007/E/01.

### **References**

- Aster, R. and Borchers, B. (2008) Time series / Dataprocessing and analysis (MATH 587 / GEOP 505).*
- Hinsch, R. T., Slaughter, D. C., Craig, W. L. and Thompson, J. F. (1993) Vibration of fresh fruits and vegetables during refrigerated truck transport. Trans. ASAE, 36, 1039–1042.*
- Holt, J. E. and Schoorl, D. (1985) A theoretical and experimental analysis of the effects of suspension and road profile on bruising in multilayered apple packs. J. agric. Engng Res., 31, 297-308.*
- HTTP://WWW.UMTRI.UMICH.EDU Pavement evaluation -Roughness.*
- Northwood-Labs-LLC (2003) GPS Carrier-to-noise density. Northwood Labs LLC.*
- Ranatunga, C. L., Jayaweera, H. H. E., Suraweera, S. K. K., Wattage, S., Ruvinda, K. K. D. L. and Ariyaratne, T. R. (2010) Vibration effects at vehicular road transportation. IPSL Annual Technical Sessions (26). Colombo, Institute of Physics, Sri Lanka.*
- Tustin, W. (2005) What is the meaning of PSD in g<sup>2</sup>/Hz units. ERI News. Santa Barbara.*
- Vursavus, K. and Ozguven, F. (2004) Determining the effects of vibration parameters and packaging method on mechanical damage in Golden Delicious apples. Turk. J. Agric. for, 28, 311-320.*